

Generation II Stack Only 6545-325 Tote

Slots for multiple divider configurations

Double wall rounded corners for smooth conveying

Optional sidewall drain holes

Designated locations for barcode labeling



Recessed, ergonomic handles offer optimal manual handling while not interfering with automated systems

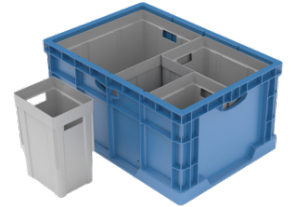

Mini Tote System Option

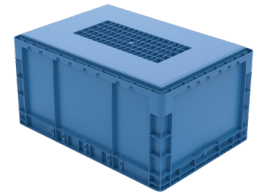

Hybrid Bottom Option

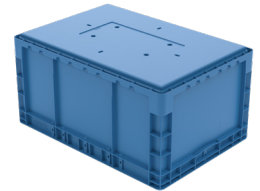

Welded Bottom Option

Additional Features:

- » Ideally suited for automated storage systems and conveyor systems
- » Designed to comply with FM Global Fire Risk Management October 2020 standard
- » Barcode label verification and database download available
- » Available in vented or non-vented sidewalls
- » Multiple interface points enable robotic handling and conveyor positioning
- » Optional divider or Mini Tote System (MTS) offer flexibility
- » Available in both COPP and HDPE material

Specifications:

Model	Outside Dimensions (mm)			Inside Dimensions (mm)			Racking Capacity (kgs.)*	Weight (lbs.)	Volume (ft ³)	Trailer Qty 53'
	L	W	H	L	W	H				
SO 6545-325 H	648	448	325	613	413	307	35	7.61	2.71	1,040
SO 6545-325 W	648	448	325	613	413	307	50	7.82	2.71	1,040
SO 6545-325 V	648	448	325	613	413	307	35	7.61	2.71	1,040

"H" denotes Hybrid Bottom, "W" denotes a Welded Bottom, "V" denotes Vented Side Walls
*Max Capacity while maintaining flatness tolerance for automated systems

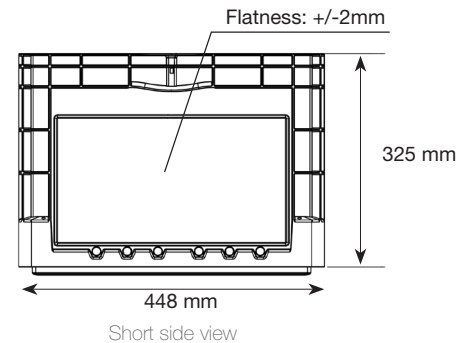
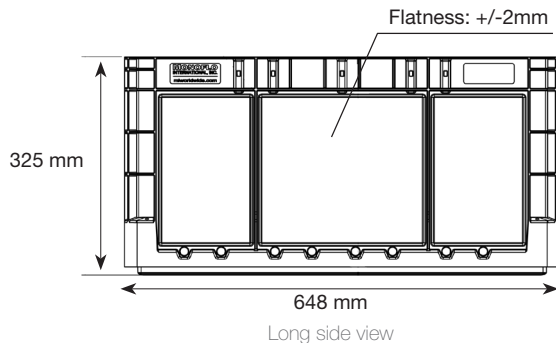

Monoflo International
882 Baker Lane, Winchester, VA 22603
Call 540-771-3077

miworldwide.com



defining what comes next.